

**Features**

- 32-channel
- 24 V DC supply
- HART field device input (revision 5 to 7)
- RS-485 interface
- Up to SIL 3 acc. to IEC 61508

**Function**

The HART Multiplexer Master provides 32 signal channels for connection to SMART transmitters or control devices supporting digital communication according to the HART standard.

Full three-port isolation is included and each input channel has dual capacitor isolation for freedom of loop connection.

Each HART Multiplexer Master is networked simply by connecting the high-speed RS 485 output in a multidrop configuration.

The device interrogates each field device, under the supervision of the workstation, retrieving information for storage in its internal database, which is then easily accessed.

This module is intended to mount on an HiD Termination Board or HART Communication Board. Also special boards for DCS integration are available.

For additional information, refer to the manual and

**Assembly**

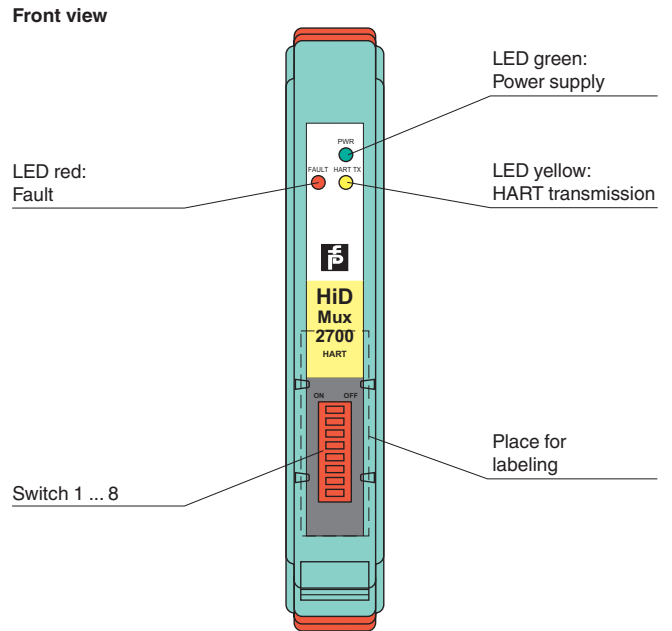

**SIL 3**



**Connection**

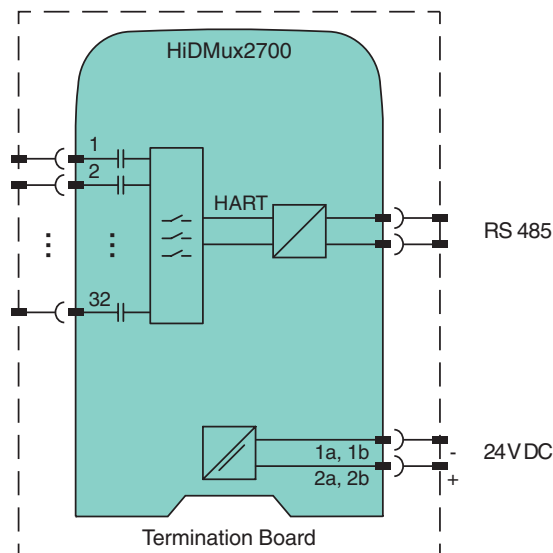

**Zone 2  
Div. 2**

Release date 2018-03-02 11:38 Date of issue 2018-03-02 211968\_eng.xml

<b>Functional safety related parameters</b>		
Safety Integrity Level (SIL)		SIL 3
<b>Supply</b>		
Connection		SL1: 1a, 1b(-); 2a, 2b(+)
Rated voltage	$U_r$	20.4 ... 30 V DC via Termination Board
Rated current	$I_r$	28 mA at 24 V , RS-485, quiescent current
Power dissipation		0.7 W at 24 V
<b>HART signal channels (non-intrinsically safe)</b>		
Number of channels		32
Conformity		HART field device input (revision 5 to 7)
Signal range		$0.12 V_{pp} < \text{signal} < 1.5 V_{pp}$
Leakage current		$< 3 \mu\text{A}$ at -20 ... 85 °C (-4 ... 185 °F)
Terminating resistor		external 230 ... 500 $\Omega$ standard (up to 1000 $\Omega$ possible)
Output voltage		$\geq 400 \text{ mV}_{ss}$ (with the terminator resistance specified above)
Output resistance		100 $\Omega$ or smaller, capacitive coupling
DC isolation		dual capacitor each channel
Common mode voltage		up to 30 V
Input impedance		$> 5 \text{ k}\Omega$ , according to HART specification
Input voltage range		$0.12 \dots 1.5 V_{ss}$
Common mode voltage		$\leq 30 \text{ V}$
Differential mode clamping		$\pm 5.2 \text{ V}$ , for transient or AC signals
Common mode clamping		$\pm 10 \text{ V}$ , for transient or AC signals
Carrier detect level		signal $> 0.12 V_{pp}$ , carrier detection activated signal $< 0.08 V_{pp}$ , carrier detection not activated
Transmit amplitude		200 $\Omega$ load, $0.43 V_{pp} < \text{signal} < 0.49 V_{pp}$ 500 $\Omega$ load, $1.1 V_{pp} < \text{signal} < 1.2 V_{pp}$
Device type		DC isolated bus device
Impedance		high impedance
Data link type		HART primary and secondary
Field multi point support		option available upon request
<b>Interface</b>		
Transfer rate		9600 MBit/s, 19200 MBit/s or 38400 MBit/s, selectable via switch
Address		1 ... 31 , adjustable via DIP switch
Type		RS-485 , differential pair and grounding
Topology		multi point, master/slave connection
<b>Galvanic isolation</b>		
Interface/power supply		500 $V_{rms}$
Interface/field channels		1000 $V_{eff}$
Power supply/field channels		1000 $V_{eff}$
<b>Indicators/settings</b>		
Display elements		LEDs LED PWR ON (power supply), one green LED LED HART TX (HART transmission), one yellow LED LED FAULT (lead fault), one red LED
Control elements		DIP switches at the housing side for: - unit slave address - baud rate - test mode on/off
Configuration		via DIP switches
Labeling		space for labeling at the front
<b>Directive conformity</b>		
Electromagnetic compatibility		
Directive 2014/30/EU		EN 61326-1:2013 (industrial locations)
<b>Conformity</b>		
Electromagnetic compatibility		NE 21:2012 For further information see system description.
Degree of protection		IEC 60529:2001
<b>Ambient conditions</b>		
Ambient temperature		-20 ... 60 °C (-4 ... 140 °F)
Relative humidity		5 ... 95 % , noncondensing
<b>Mechanical specifications</b>		
Degree of protection		IP20
Mass		approx. 140 g
Dimensions		18 x 106 x 128 mm (0.7 x 4.2 x 5 inch)
Mounting		on Termination Board

Release date 2018-03-02 11:38 Date of issue 2018-03-02 211968\_eng.xml

Data for application in connection with hazardous areas	
Certificate	CML 17 ATEX 3337 X
Marking	Ⓔ II 3G Ex ec IIC T4 Gc
Directive conformity	
Directive 2014/34/EU	EN 60079-0:2012+A11:2013 , EN 60079-7:2015
International approvals	
CSA approval	
CSA certificate	1256050
Approved for	Class I, Division 2, Groups A, B, C, D and non-explosion hazardous area
IECEX approval	
IECEX certificate	IECEX CML 17.0178X
IECEX marking	Ex ec IIC T4 Gc
General information	
Supplementary information	Observe the certificates, declarations of conformity, instruction manuals, and manuals where applicable. For information see

## Configuration

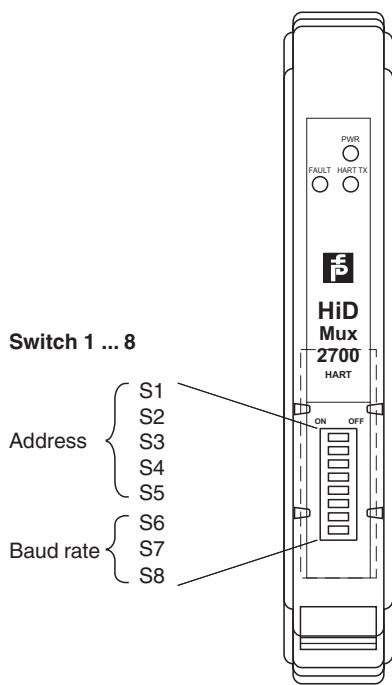

RS 485 address					
	S1	S2	S3	S4	S5
1	ON	OFF	OFF	OFF	OFF
2	OFF	ON	OFF	OFF	OFF
3	ON	ON	OFF	OFF	OFF
4	OFF	OFF	ON	OFF	OFF
5	ON	OFF	ON	OFF	OFF
6	OFF	ON	ON	OFF	OFF
7	ON	ON	ON	OFF	OFF
8	OFF	OFF	OFF	ON	OFF
9	ON	OFF	OFF	ON	OFF
10	OFF	ON	OFF	ON	OFF
11	ON	ON	OFF	ON	OFF
12	OFF	OFF	ON	ON	OFF
13	ON	OFF	ON	ON	OFF
14	OFF	ON	ON	ON	OFF
15	ON	ON	ON	ON	OFF
16	OFF	OFF	OFF	OFF	ON
17	ON	OFF	OFF	OFF	ON
18	OFF	ON	OFF	OFF	ON
19	ON	ON	OFF	OFF	ON
20	OFF	OFF	ON	OFF	ON
21	ON	OFF	ON	OFF	ON
22	OFF	ON	ON	OFF	ON
23	ON	ON	ON	OFF	ON
24	OFF	OFF	OFF	ON	ON
25	ON	OFF	OFF	ON	ON
26	OFF	ON	OFF	ON	ON
27	ON	ON	OFF	ON	ON
28	OFF	OFF	ON	ON	ON
29	ON	OFF	ON	ON	ON
30	OFF	ON	ON	ON	ON
31	ON	ON	ON	ON	ON

RS 485 baud rate			
	S6	S7	S8
9600	OFF	OFF	OFF
19200	ON	OFF	OFF
38400	OFF	ON	OFF

Release date 2018-03-02 11:38 Date of issue 2018-03-02 211968\_eng.xml

## Additional information

### Conformity

The HART Multiplexer Master generally complies with the HART FSK physical layer specification rev. 8.0 available from the HART Communication Foundation. HART is a registered trademark of the HART Communication Foundation.

### High specification front end design

Two decoupling capacitors are provided, one for each signal connection. Both the positive (+U<sub>e</sub>) and the negative (-U<sub>e</sub>) signal wires are therefore decoupled from DC signal. Only the high frequency digital HART protocol signal passes through to the internal multiplexer circuitry.

Failure of any one capacitor from either a short circuit or open circuit means that availability of 4 mA ... 20 mA control signal will not be affected.

- no DC loading of 4 mA ... 20 mA control signal
- no single point of failure
- high noise immunity

The max. 30 V DC input voltage (specified between all terminals, both belonging to the same channel or not) makes it possible to connect any multiplexer terminal to whatever voltage level can be derived from a 24 V DC supply, +20 % tolerance included.

### Three port isolation

The three port isolation structure of the HART Multiplexer Master is depicted in the previous page. As you can see, both the 24 V supply input and the RS 485 serial interface are isolated from the HART section, i. e. from the HART signals on the field devices. This is full galvanic isolation, implemented either by transformer or by optocoupler.

### Self contained architecture

Each HART Multiplexer Master module is a stand alone device containing all necessary hardware to communicate with up to 32 HART protocol enabled field devices and a host PC via RS 485 interface. The advantages are:

- fast polling
- one module design
- RS 485 direct from module
- no communications bottleneck
- ideal for valve diagnostics

### Wide software compatibility

The HART Multiplexer Master is fully compatible with F-R AMS (Ver 5.0 is also an OPC server), Valve Link and Cornerstone.

Additional compatibility extends to HART OPC server software available from HCF (HART Communication Foundation). Allowing users to write dedicated applications for their specific needs.

Fully tested, by all key PAM vendors.